



guided micropulse level indicator PulsFox® PMG 20 MF -61

Part no. 56540610-L-101

Guided micropulse level indicators

benefits

- Level measurement independent of changes in pressure, temperature or density
- stable, reliable measurement even with foam, vapour, dust or turbulent surfaces of the medium
- robust housing for rough ambient conditions
- maintenance-free, not subject to wear and tear

Application

For universal continuous level measurement in containers, tanks or silos. Suitable for liquid, powdery, electrically conductive or non-conductive media. Ideal for changing media. FEP-coated and PFA-coated probes are available for corrosive, highly clean media or food. Also suitable for pressurised or vacuum tanks. The device can be easily adjusted by means of the programming display with user-friendly menus; it also serves as a local display.

Description

PulsFox® PMG 20 level indicators operate on the basis of the guided micropulse principle (TDR, time domain reflectometry). A micropulse is emitted along a probe. The micropulse is surrounded by an electromagnetic field. Reflections of the pulses from objects and surfaces serve as the basis of distance measurement. The pulse's propagation time is directly proportional to the distance between the probe and the surface of the medium. The reflectance of materials depends on the dielectric constant ϵ_r . Changes of the medium such as, for example vapour, dust or a turbulent surface do not affect the measuring accuracy of this measuring principle. No recalibration is required when a different medium is used. Even if properties such as pressure, temperature and density change, the system operates with high reliability and precision. PulsFox® PMG 20 has no moving parts and is therefore maintenance-free and not subject to wear.

Technical Specifications

max. measuring range

MF-61

≤ 12000 mm

(specify exact probe length when ordering)

dielectric constant (ϵ_r) of medium

MF

≥ 2.1

Measuring accuracy

MF

± 4 mm ≤ 2 m

± 2 mm > 2 m

Operating temperature range

Medium: -40/+300 °C

Flange: -40/+85 °C

Ambient: -30/+70 °C

Process pressure

MF

max. 10 bar

Process connection

G1B, Stainless steel 316 Ti

Supply voltage

DC 18 – 36 V

Options

- other process connections
- FEP/PFA coatings
- EX version Ex II 1/2 G Ex ia IIB T5 Ga/Gb

Output signal

4–20 mA/HART, 2-wire

material

Probe head: aluminium die cast

MF

Stainless steel 316 L

Degree of protection

IP 67 (EN 60529)

Electrical connection

Cable gland M16 x 1.5

Technical Drawings

PulsFox® PMG 20 MF - 61 with flexible mono probe (FEP/PTFE insulation)

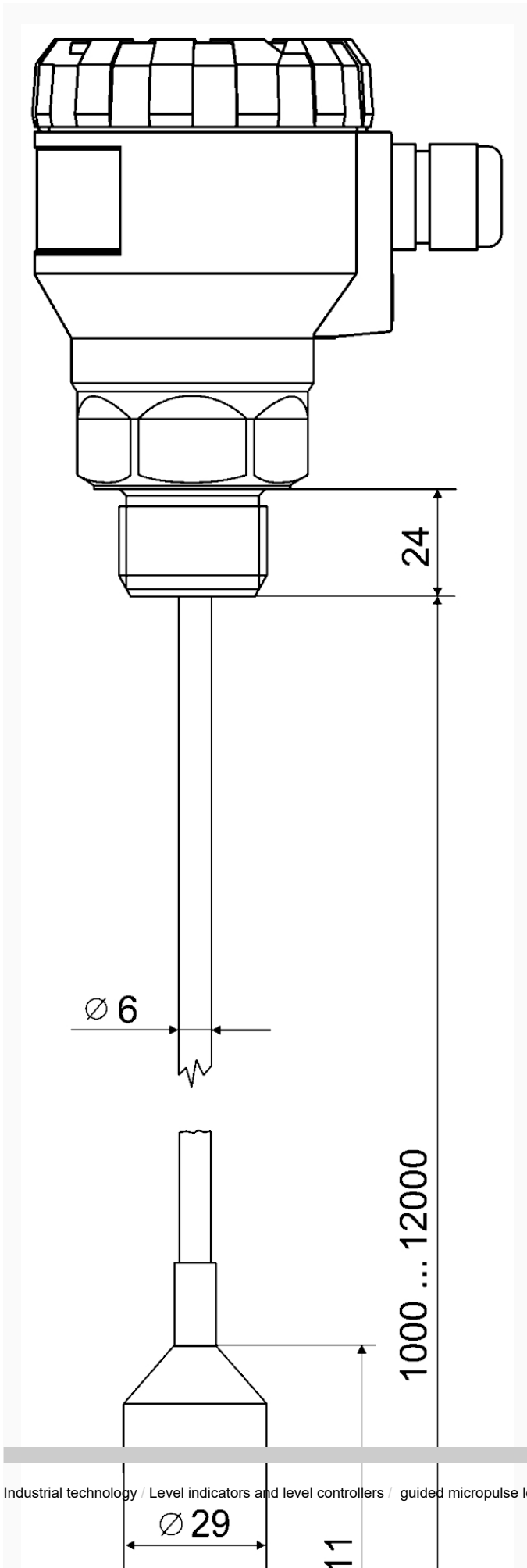

Versions

	Part no.
PulsFox® PMG 20 MF -61	5654061O-L-101

- in-stock items
- Non-stock items